

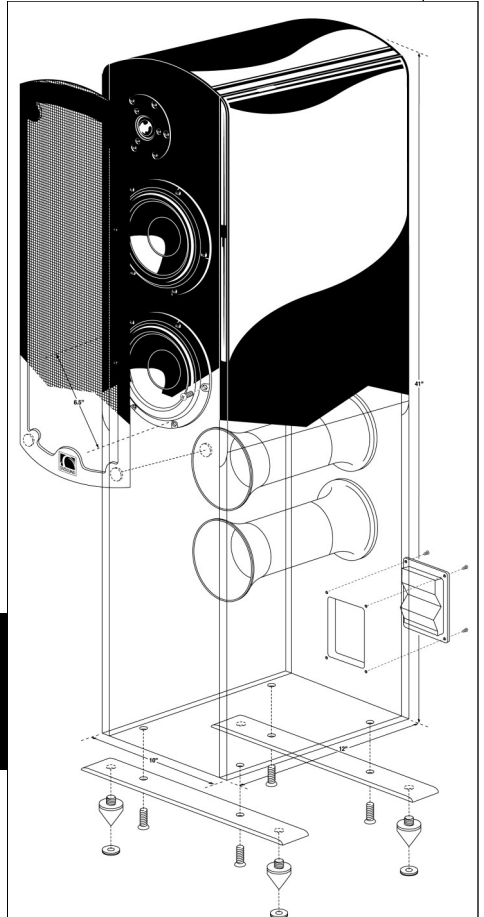

OWNER'S GUIDE

**SVS Family of
Speakers: SBS-01,
SCS-01 and MTS-01**



Contents:

- Chapter 1 - Welcome
- Chapter 2 - Safety
- Chapter 3 - About your SVS speakers
- Chapter 4 - Speaker placement
- Chapter 5 - Room diagrams: 5.1 and 7.1 channel
- Chapter 6 - Wiring
- Chapter 7 - Speaker orientation
- Chapter 8 - Tweeter attenuation (MTS-01 only)
- Chapter 9 - Port tuning (MTS-01 only)
- Chapter 10 - Audio system configuration
- Chapter 11 - Channel level calibration
- Chapter 12 - Speaker specifications
- Chapter 13 - Warranty

Last update: 30 September, 2008

Welcome: Congratulations on your purchase of these high-performance SVS audio speakers.

At SVS, you can actually *hear* the tireless research and design efforts built in to our speakers. Years are spent developing any SVS product — with work typically spanning from our Ohio headquarters... to US west coast technology centers... and over to the finest component suppliers in Asia and Europe as well. Nothing in our speaker offerings is an “off the shelf” product. SVS is committed to making better sound systems with elegant looks, robust construction and world-class technology and materials. We believe you deserve nothing less.

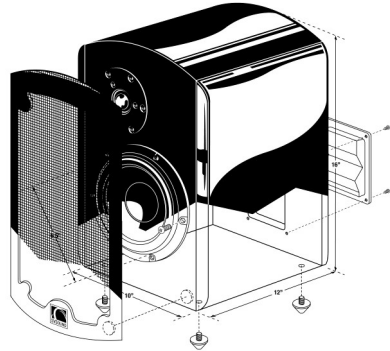

This manual and the printed “Quick Start” sheet will help you integrate these speakers with your subwoofer quickly and with professional results.

Armed with only a few basic tools, such a sound pressure level (SPL) meter, and the test tones built in to most audio/video receivers (AVR), you will achieve smooth, detailed and powerful reproduction of all your favorite music and movie audio. Expect to hear things you never heard before... and expect *not* to hear some of the artifacts you might have accepted in the past with inferior speakers.

Have a question about your surround sound system? For more discussion about speaker or subwoofer setup check out our website or that of your exclusive regional SVS's Dealer. Contact us via phone, e-mail or fax should you have any question regarding our products.

SVS was founded by audio enthusiasts — our commitment to service is the only thing that rivals the products we create. Our resellers around the world feel the same way.

**The SVS Team, Ohio, USA
March, 2008**

IMPORTANT SAFETY INSTRUCTIONS

1. Read these instructions.
2. Keep these instructions.
3. Heed all warnings.
4. Follow all instructions.
5. Do not use this apparatus near water.
6. Clean only with dry cloth.
7. Do not block any ventilation openings. Install in accordance with the manufacturer's instructions.
8. Do not install near any heat sources such as radiators, heat registers, stoves, or other apparatus (including amplifiers) that produce heat.
9. Do not defeat the safety purpose of any polarized or grounding-type plug. A polarized plug has two blades with one wider than the other. A grounding type plug has two prongs and a third grounding point. The wide blade or the third prong are provided for your safety. If the provided plug does not fit into your outlet, consult an electrician for replacement of the obsolete outlet.
10. Protect your power cords from being walked on or pinched particularly at plugs, convenience receptacles, and the point where they exit from the apparatus.
11. Only use attachments/accessories specified by the manufacturer.
12. Use only with the cart, stand, tripod, bracket, or table specified by the manufacturer, or sold with the apparatus. When a cart is used use caution when moving the cart/apparatus combination to avoid injury from tip-over.



13. Unplug this apparatus during lightning storms or when unused for long periods of time.
14. Refer all servicing to qualified service personnel. Servicing is required when the apparatus has been damaged in any way, such as power-supply cord or plug is damaged, liquid has been spilled or objects have fallen into the apparatus, the apparatus has been exposed to rain or moisture, does not operate normally, or has been dropped.
15. **WARNING:** To reduce the risk of fire or electric shock, this apparatus should not be exposed to rain or moisture and objects filled with liquids, such as vases, should not be placed on this apparatus.
16. To completely disconnect this equipment from the mains, disconnect the power supply cord plug from the receptacle.
17. The mains plug of any power supply cord shall remain readily operable.



The lightning flash with arrowhead symbol within an equilateral triangle, is intended to alert the user to the presence of un-insulated "dangerous voltage " within the product's enclosure that may be of sufficient magnitude to constitute a risk of electric shock to persons.



The exclamation point within an equilateral triangle is intended to alert the user to the presence of important operating and maintenance (servicing) instructions in the literature accompanying the product.

About your SVS speakers:

Un-box your speakers and you will immediately be impressed with several things. First, our components are of exceptional quality: from synthetic rubber surrounds to the elegant trim rings. With stylish touches like real wood veneer, they look as good with the matching fabric grilles off as they do on.



Expensive tweeters and hand-built crossovers result in a very natural sounding yet powerful speaker, which will stand up to any music or movie audio you send to it. Notice too, the simple yet modern design details, such as smooth “seamless” corners and magnetized grill retainers. These are just a few of the *dozens* of parts our factory-direct sales model provides you, at prices virtually no other major brand can match.



What is *not* visible is, of course, often more important than what is visible. And SVS is long known for including features you might never see!

display. And those heavy cabinets bolstered internally with computer cut braces. Pick up any SVS speaker and you will notice immediately just how heavy they are. This is quality you can hear, and feel.

All our speakers are shielded for use near any sort of video are acoustically damped and

Sometimes, looking at the back of a product tells you still more about the care that went inside too. We never use crude surface-mounted binding posts. Every part is flush fit into your speaker with precision and care. Note threaded inserts and special rubber or metal feet for secure placement in a variety of home environments.



The costly finishes on our famous speakers are already legendary for providing attractive designs that will withstand the rigors of use around the world. High grade polymer laminates, hand-finished gloss and real wood veneers ensure your speakers complement your décor for years to come.

Location, location, location: Properly set up in a typical home, your SVS speaker package, backed by a high quality subwoofer, will provide startlingly realistic reproduction of any sort of music or movie soundtrack.

Take time to carefully unpack everything. Look thoroughly in each box. Locate all the items you'll need to proceed to installing your speakers (tools, wire, wall brackets, SPL meter, etc.). Save the box and shipping materials, just in case you need to return a component or move your system to a new home.

Where you put your speakers can be just as key as how well they are designed! Discussions in this section of your manual are meant to provide general guidance. We encourage some experimentation in placement as your time and room allows.

Later, we will also review your receiver or audio processor settings, and touch on DVD or CD player internal settings too, which can affect sound just as where you place your speakers will. In the final chapter we outline how to achieve a realistic blend between all your speakers and your sub.

Speaker Placement: Any speaker tends to benefit from placement spaced somewhat from rear or side walls. Ideally you should arrange to have all tweeters (the small element in your cabinet) at "ear height", or tilted to point towards your seats. Attempt to place them so you sit an equal distance from each speaker cabinet.



Placing your SVS speakers within your room



As you unpack them, you will notice a variety of ways to securely place your speakers inside your listening room. You can put bookshelf speakers on optional stands or brackets, and of course, bookshelf and center channel speakers can also be put on any convenient shelves in your home.

Setup and room integration:

So, there are many ways to put these speakers someplace in your home. However those particular places will have a significant impact on the sound heard at your primary listening positions. Again, where possible, try to keep speakers roughly the same distance from the floor. Using a combination of speaker stands, brackets or shelves, should allow center-channel speaker and main channels to keep the tweeter/woofer assemblies at the same level.

The next Chapter shows a top view of a room in 5.1 channel surround sound installation and then a typical 7.1 channel setup. Notice the speakers are away from back and side walls, and they are angled a bit so that a convincing sonic “image” is achieved even if you use your system for two channel stereo music. When optimized for your room, you should be able to hear sound even to the right and left of each speaker, which enhances the spaciousness of the front “soundstage”.



Note the location of the “rear” speakers in the next Chapter as well. Also called “surround speakers”, they tend to be the most difficult to place in rooms. Higher placement, using brackets with downward tilt (aiming towards the listening area) is often required and is an acceptable compromise when speaker stands are impractical. Consider foot-traffic in your room and ensure you, children or pets are not likely to tip over your SVS speakers, or alternatively bumping their heads on our rather stoutly built speaker cabinets!

Speaker placement: 5.1 versus 7.1 channel



5.1 channel surround-sound systems employ Right, Center, Left, and Left Surround and Right Surround speakers, *plus* a Subwoofer. This basic “theater” configuration is depicted in the next Chapter.

Such systems are being supplanted by 7.1 channel systems shown in the second room diagram.

The differences in sound between 5.1 and 7.1 channel audio systems can vary significantly, with larger rooms usually benefiting from the added speakers more than smaller rooms.

The practical differences between the two common surround-sound configurations are probably obvious. Not only does a 7.1 system require more speakers, but a somewhat different room-placement strategy.

With 7.1 systems, there are “back” speakers roughly centered on the rear wall of your room. The “surrounds” then are usually pulled forward from the back wall some, and often placed in line with your seats, or just behind.

Note: a 7.1 channel audio/video receiver (AVR) can be readily configured to do a 5.1 channel setup, using the AVR’s setup menu to designate what speakers are present. However, the reverse situation is not true. A receiver that is “only” equipped with 5.1 channel processing can not be used in a 7.1 channel configuration.

Check your surround sound receiver/processor for additional guidance. Not all AVR’s work precisely the same with regards to the methods used to create the rear channel sound fields. Thus some receiver brands will suggest somewhat different placement.

Once you have your speakers placed throughout the room we can move on to wiring them up, then system configuration, and finally channel level calibration.

Speaker placement: 5.1 Channel Surround Sound System

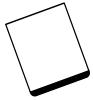

Left Front



Center



Right Front

**Typical 5.1 Channel
Speaker Placement**

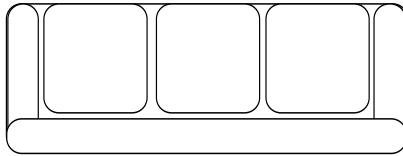

Left Surround



Right Surround

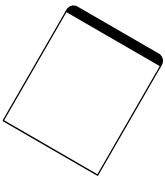

Subwoofer

Speaker placement: 7.1 Channel Surround Sound System

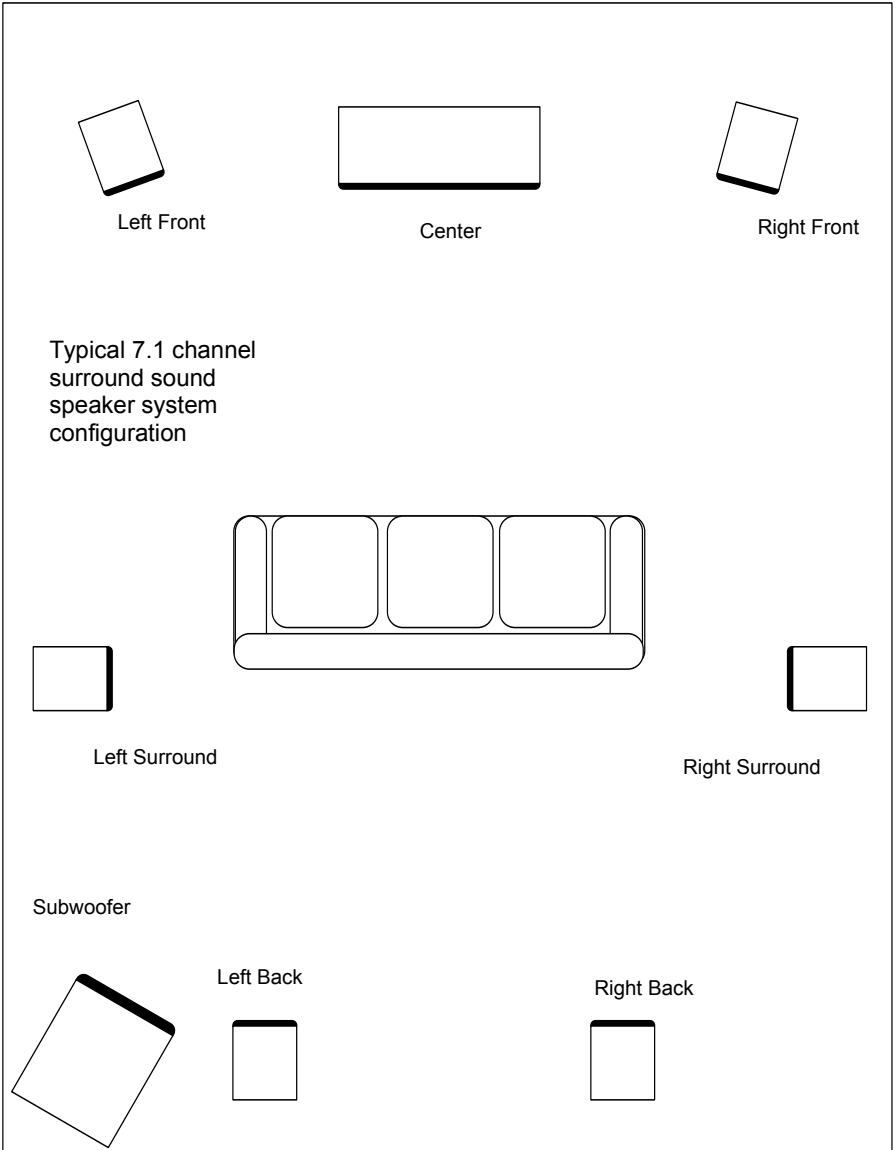

Speaker wiring: Exceptional care must be used at this stage to ensure details are not overlooked. Check everything closely as you wire things up, then “double check” each aspect of your connections before you move on.

First, review the printed **Quick Start Guide** and note the simplified wiring diagram which should allow you to visualize your system’s connections. The diagram in the guide shows a 5.1 channel configuration with a typical AVR that’s actually capable of powering an additional set of rear/back speakers in 7.1 channel fashion.



Next, be sure everything in your system is turned off and unplugged from electrical power.

Now, study the speaker wire you have purchased. For long runs over 5-10 meters we recommend “12 gauge” wire. For shorter runs, “14 gauge” is adequate. If you bought wires from your SVS dealer, you will notice the red/black color coding on the ends of the wires.

Observe that on the back of your speakers are “binding posts” which are likewise colored. Probably the back of your receiver or amp is also marked in this manner. Red is universally “+” or “Positive” in polarity. In contrast notice that Black is “-” or “Negative” polarity. The thin “banana” plugs are meant for the AVR side of your audio connections. The flat “spades” are best for connecting the speaker binding posts themselves.

It is critical that you **not** have stray strands of wire which allow Red (+) and Black (-) to touch each other either at the receiver, or the speakers. Also vital is the need to keep polarity correct. By “polarity”, we mean that if you trace *any* wire from your receiver’s Red positive (+) connection it *must* lead to the positive (+) Red terminal on the properly matched speaker. Naturally, Black must lead to Black too.

Now, not all wire is so cleverly color coded. Good quality copper wire from any hardware store can work well, but may require you to look more closely at the wire, or insulating jacket. Often times the jacket itself is marked with printing or a thin color thread to allow you to keep polarity in your system lined up.

Connections, phase, wire and more

Regardless of the sort of wire you use, keep a consistent approach to your wiring so you do not inadvertently mismatch your Plus (+) or Negative (-) terminals on any speaker and its run to the receiver's speaker outputs.

After tightening down your speaker terminals it's important to periodically check on them. If you are using bare, stripped wire you may notice it will tend to flatten over time. Loose connections at your speaker binding posts can be a result.

Again look at the diagram on the printed **Quick Start** sheet to get an idea of how you should configure wiring with a typical AVR and a basic surround-sound system.



Your speaker is “bi-wire” and “bi-amp” capable with gold-plated bars installed as a default for use with most consumer audio systems. Bi-wiring your speakers (and removing the bars connecting the two sets of binding posts) is unlikely to produce an improvement in sound quality, but this configuration is often the choice of discerning audiophiles. While not necessary for excellent sound, bi-amping your speakers may result in better performance, with improved headroom and dynamic range.

The upper terminal set is for the tweeter, and the lower terminal set is for the mid-bass driver(s). Be sure to maintain correct wiring polarity (+ to +, - to -) for all connections.

Speakers with “mirrored” tweeter: MTS-01 and SCS-01

In any audio system, your room’s shape and the position of any speaker in that room, plus your own position, all affect the way sound which reaches your ears.

Sound bounces off of walls, or it can be absorbed by nearby furniture or floor coverings. Moving a speaker or subwoofer a few feet, sometimes only inches can have subtle or even significant audible consequences, so experimentation is recommended. Physical position in one’s room is perhaps the most obvious setup aspect you might vary.

A second placement aspect is “toe” or pointing your speakers at least partially towards primary listeners. This technique can vary the sense of space and precise “imaging” of sounds in your room.

With “mirrored” speakers such as MTS-01’s, there is a third consideration:

Tweeter location. One look at your speakers will indicate you have two options: “tweeter in” or “out”. Try both options. Side reflections from walls, along with “toe” will serve to prompt subtle shifts in how

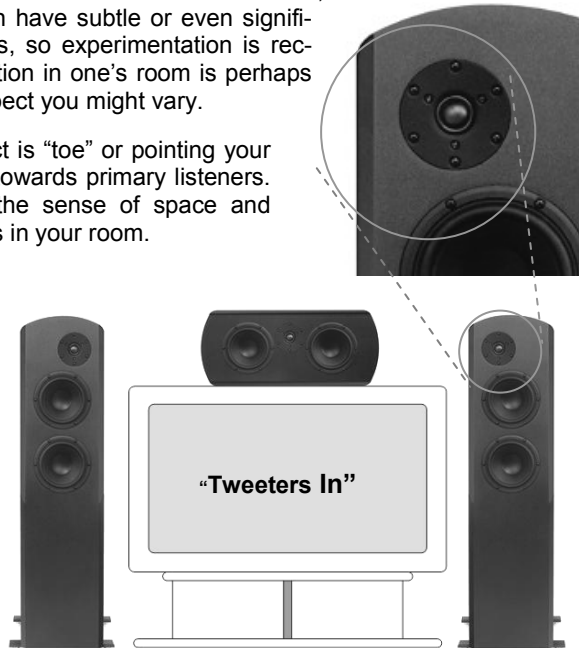

your soundstage is rendered. You might find no substantive difference in your sound with changes to placement, toe or tweeter orientation. Yet if you move to another room, changes can be striking. Take a moment to see which situation applies in your room and contact your dealer if you have any questions about these versatile speakers.

Tweeter Attenuation Control: Placed inside your binding post cup in the back of your speaker, the standard tweeter switch setting (0dB)



is best for medium to large rooms with typical levels of acoustic damping (curtains, upholstered furniture, carpeting), or for small

rooms which are acoustically treated with panels and diffusers.

In rooms without acoustical treatments, and which have a significant percentage of exposed and highly reflective surfaces (drywall, brick, glass), you may find the standard tweeter setting too “bright” and accentuated. In such instances, try the attenuated tweeter setting, which mitigates some of the extreme high frequencies and will sound “softer” as a result.

Evaluate the two modes using music which you know well. Ultimately your personal preference will dictate the optimal tweeter switch setting.

The red trace below is the “flat” 0dB tweeter setting, blue is with the -3dB attenuation selected.

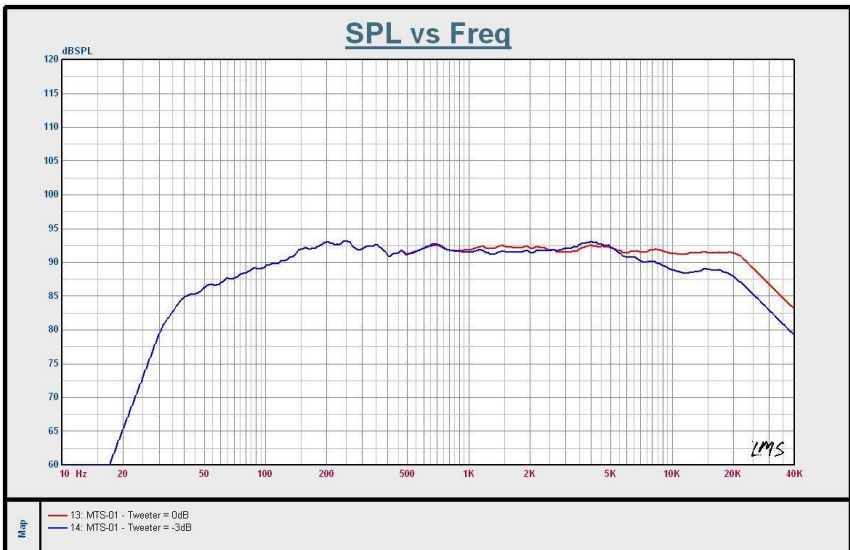



MTS-01 Speaker family port tuning

Your MTS-01 speaker family (including the MCS-01 and MBS-01) can be run in either their efficient and deep “vented” configuration (using no foam port plugs). Or “sealed” with their rear-located ports filled by the included plugs.

For most applications, we recommend the vented mode with the speakers set to “Small” in your AVR’s setup menu, along with an 80 Hz bass management setting as well. Depending on the room acoustics and the slope of the high pass filter in your AVR, you may find that sealed mode with a 100 Hz bass management setting provides better results in the mid-bass regions. We encourage you to audition both modes and crossover frequencies to determine what sounds best in your system and room.

Blue trace below is sealed mode. Red trace shows open ports.

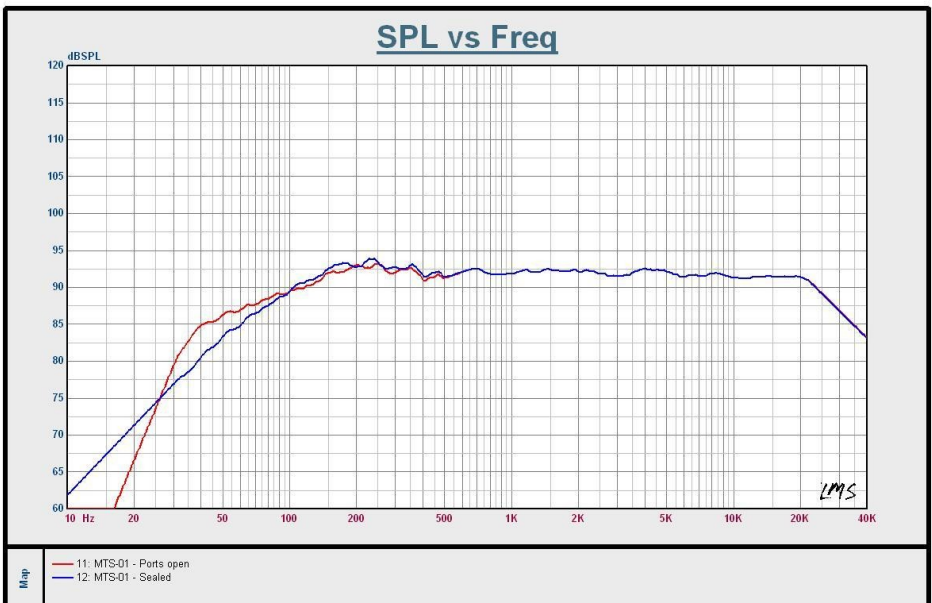

Audio/Video System Configuration:

The most important things to know about your speakers are in this document, but find your AVR and your DVD or CD player manuals too. We recommend you reacquaint yourself with the setup menu options in each of these important pieces of audio gear. Even speakers as fine these from SVS will not sound correct if poor choices are made during system configuration.

Becoming familiar with the setup menus of your AVR and DVD player usually requires your primary video display show all settings easily (some receivers only offer front panel displays for this).

DVD player: Frequently, DVD players ship with their digital audio outputs *not* configured to send Dolby Digital and DTS audio to your AVR. Go into your setup menu and see how your player is set up. **Note:** If you use a Dolby Digital capable AVR, your DVD player should be connected with ONLY a single-element RCA to RCA “interconnect”, or an optical cable. Avoid using the “Right/Left” *analog* audio outputs of any DVD player. These outputs will not provide the high fidelity sound from your movie or music disks which digital signals provide.

Within DVD player setup menu for digital audio, the digital output on should be enabled and also set to “BITSTREAM” (or in some cases simply annotated as “Dolby Digital”). Ensure this setting is *not* on “PCM” which is the secondary audio track on virtually all DVD’s, (but with inferior sound relative to Dolby Digital or DTS). Often “DTS” is a sound menu selection and should be enabled too if your AVR is compatible with this alternative audio format.

If you have purchased a high-definition Blu-ray disk™ player, or even the latest generation standard-definition DVD players, you may be able to use an “HDMI” cable to send digital video *and* audio via that single connection. Consult your player’s guide for the various options offered to exploit the newest audio formats on Blu-ray™ . These include “Dolby Digital Plus” and “Dolby True HD” which can provide even better fidelity and press the capabilities of your speakers and subs even more than ever!

On your receiver: There are often confusing and even conflicting settings in a modern AVR. The basics of proper audio setup are quite simple however.

First, make sure all speakers actually installed in your system are also selected in the receiver setup menu. Of course if you do not have any particular speaker (say surround “back” speakers in a 7.1 system), then these should be set to “Off” or “No” ... so your sound is processed properly. Second, ensure the “size” of the speakers are correctly noted in your AVR. In most instances, a system which also includes a high-quality subwoofer will produce better sound with all speakers set to “Small”.

Note: Virtually every consumer audio speaker system, including those from SVS, requires a quality subwoofer to achieve “full range” sound reproduction. We recommend you configure speakers in your AVR to “Large” **only** if you have **no** subwoofer. Add an SVS sub to your system for superior clarity, depth and dynamic range.

If adjustable in your AVR, set your bass management (a sort of electronic crossover built into your receiver) to 80hz. This eases the deep bass burden on your speakers and uses your subwoofer properly too. In some AVR’s your “LFE” (“low frequency effects”, the “.1 channel”) can be routed to the subwoofer *and* your Right and Left main speakers. Do not use this feature. LFE should be directed to the subwoofer only.

Be sure to set the “distance” figures for each speaker correctly too. Use a tape measure to determine what these distances are. If there are any “peak limiters”, DRC circuits, or “Mid-night mode” options, disable all these too. Your SVS speakers can handle the widest dynamic range possible and “compression” modes should be avoided.

Finally, a word about modern AVR “auto-setup” routines: Many AVR’s today include microphones which can be used to optimize speakers with a corrective equalization profile. Such systems will set speaker “size” and the level (loudness) of each speaker. These systems can and do make mistakes however.

We *highly* recommend you “double check” the results of any such auto-setup scheme. If your speakers are set to “Large” for instance, go back into the setup menu and change back to “Small”, and consider using a consistent 80hz AVR menu selection for all speakers. Use a sound pressure level (SPL) meter with the AVR’s test tones to validate channel levels as well. More on this critical audio setup step in the next chapter.

Speaker “Level Calibration”: In home audio, “calibration” is simply a method to ensure “all speakers play back the same volume when the same volume signal is fed to each. Correct speaker playback levels are critical to reproducing the “soundstage” intended by the musical artist or movie director. This calibration section is common with SVS subwoofer manuals. Even with “auto-setup” routines included in today’s AVR’s, it is important to validate and adjust channel balance.

As always, we recommend consulting your manual to refresh on the procedures to vary individual channel levels and use the test tones built into any AVR. Usually you can do this just by using the correct keys on your receiver’s own remote control. Purchase a basic SPL meter and you have everything you need to achieve professional setup results!

System configuration review prior to calibrating channel levels:

- **Are your speakers set correct to the correct “size”?** Your AVR should allow of “Small” or “Large”, which enables “bass management” in your sound system. Selecting “Small” with typically ensures most of the “mid-bass” goes to your room’s speakers, with deep bass going to the sub.
- **Also, is your AVR’s subwoofer output jack enabled?** This will only happen if you indicate “Yes” (or “ON”) in the speaker configuration selection of your AVR’s setup menu.
- **Is your receiver connected to the sub amp?** Use a well-shielded “RCA cable”, sometimes called an “interconnect” to link the subwoofer output of your AVR to one RCA input jack of any SVS subwoofer amplifier. You will need to “split” the AVR’s subwoofer signal with a “Y Cable” if you bought a pair of subs. Talk to your SVS Dealer for more info on twin subwoofers.
- **Switch on your Radio Shack® sound pressure level (SPL) meter.** Seen above, this tool is absolutely essential to proper surround audio setup. An SPL meter is akin to a tire pressure gauge for your car. Set the meter to “Slow” and “C-weighting”, and turn the dial to 70 or 80dB, depending on your test tone source.



- **Getting ready to start:** Make sure your receiver/processor master volume is set at “00 dB” **or some other easy to remember reference level**. Set your subwoofer’s volume/gain control to no more than 1/3rd up for now (it can be turned up later).
- **Check the subwoofer level control of your AVR before you begin the test tones.** Initially set your receiver’s dedicated subwoofer output control no higher than “-3 dB” given a typical receiver’s subwoofer channel level limits of -12dB to +12dB). Turn off any sound processing schemes such as “midnight mode”, “Dynamic Range Compression” (DRC) etc. Finally, ensure your AVR is in Dolby Surround/Dolby Digital playback mode.
- **Put your SPL meter on a tripod**, or hold it in front of you, with the meter angled upward at 45 degrees. It should remain in this position for all channels (do not point the meter at each speaker playing).
- **Now play your receiver’s internal test tones so you have something to measure with your SPL meter.** Or, use a test DVD such as the *Avia*, which can yield even more accurate channel calibration results than AVR test tones. A test tones from *Avia* will ensure your entire audio signal path, from the DVD player to your speakers, is set correctly.
- **Watching your sound meter now:** when the test tones start alternating from speaker to speaker, use your AVR remote control to set each speaker’s volume to about 75 dB (Note: 85dB if using *Avia*). You should only adjust the AVR’s dedicated channel level controls and leave receiver’s master volume control untouched.
- **If your readings for the subwoofer are high** (more on this in a moment), we recommend you turn down the receiver’s subwoofer output level before you significantly lower your sub’s volume/gain control. This helps keep distortion sent to your subwoofer to a minimum. You should not set the AVR’s subwoofer level control lower than - 6 dB however, since some provision for further downward adjustment by your AVR’s remote control should be maintained. If your subwoofer SPL reading is too low, raise the gain at the subwoofer amp before changing the AVR settings.

- **But what's "too high" for your subwoofer??** Tastes vary, and so do movie soundtracks, but if you purchased an SVS subwoofer, it's capable of tremendous levels of low distortion, low frequency bass — often much more than most subwoofers. Take advantage of this, especially if you like action movies with lots of bass action. You can do so by allowing your subwoofer levels to rise a couple dB's louder than your other speakers during your level calibration. Since most audio enthusiasts don't watch movies at full theater playback levels, this often yields a more satisfying movie and music experience.
- **What subwoofer levels do we recommend?** If you purchased an SVS subwoofer, and watch movies at relatively moderate sound levels, audition a range of +1dB to +3dB above your other channels (as measured with your SPL meter). This means the test tone will waiver about 78dB for the subwoofer portion of the calibration run (88dB with Avia). (**Note:** You may want to rotate the sound meter SPL meter dial to 80dB to get a good reading with these higher levels.)
- **The above is a guide... experiment!** The louder your master volume though, the more you should back off the subwoofer's level to compensate. Audible distress is a sign to lower things a bit. Avoid your driver bottoming, resulting in a loud "clack"!
- **Location and measurement.** You should take the above measurements from your typical preferred seat for watching movies. Be advised, strong bass levels can vary tremendously simply by moving your seat, or your subwoofer, only a few feet. Such is the nature of long wave-length, low bass sound. Do not hesitate to try different locations and different playback levels for your subwoofer.
- **Setting levels for the subwoofer which are too high (and often, too low) is the most common audio system setup error.** If you make any changes to your system configuration, or move your speaker or subs, you should always run your AVR test tones to validate channel levels a final time. If you ever hear a hard "clack" from your subwoofer during movie or music playback, you should immediately turn down your subwoofer level control at the AVR, or the subwoofer's own gain control, or both.

Specifications

Model Name	MBS-01
Configuration	Mid-sized Bookshelf Speaker
Design	Bass-reflex (with port plugs for sealed mode)
Dimensions	16" x 10" x 13"
H x W x D	406mm x 254mm x 330mm
Weight	27lbs (12kg)
Drivers	Tweeter: 1" (25mm) ScanSpeak® "AirCirc" Woofer: 6.5" (165mm) Nomex® cone
Frequency Response	60Hz - 30kHz ± 3dB
Nominal Impedance	8Ω (Ohms)
Sensitivity	85dB
Power Handling	20W - 250W
Magnetic Shielding?	Yes
Mounting Options	Threaded inserts for wall bracket Surface mount with rubber feet Compatible with speaker stands
Enclosure Material	Medium Density Fiberboard (MDF) with internal bracing
Finish	Charcoal black laminate with wood veneer or gloss accent panels

Specifications

Model Name	MCS-01
Configuration	Mid-sized Center Speaker
Design	Bass-reflex with sealed mode
Dimensions	10" x 24" x 13"
H x W x D	254mm x 610mm x 330mm
Weight	39lbs (17kg)
Drivers	Tweeter: 1" (25mm) ScanSpeak ® "AirCirc" Woofer: Twin 6.5" (165mm) Nomex ® cone
Frequency Response	65Hz - 30kHz ± 3dB
Nominal Impedance	6 Ω (Ohms)
Sensitivity	89dB
Power Handling	20W - 250W
Magnetic Shielding?	Yes
Mounting Options	Wall Bracket (two Omni 20 or equivalent) Surface mount with foam-disk feet
Enclosure Material	Medium density fiberboard with internal bracing
Finish	Charcoal black laminate with wood veneer or gloss accent panels

Specifications

Model Name	MTS-01
Configuration	Mid-size Tower Speaker
Design	2 ½ way bass-reflex with sealed mode
Dimensions (Grills included)	41" x 10" x 13"
H x W x D	1041mm x 254mm x 330mm
Weight	60lbs (27.3kg)
Drivers	Tweeter: 1" (25mm) ScanSpeak ® "AirCirc" Woofer: Twin 6.5" (165mm) Nomex ® cone
Frequency Response	60Hz - 30kHz ± 3dB
Nominal Impedance	6Ω
Sensitivity	91dB
Power Handling	20W - 250W
Magnetic Shielding?	Yes
Mounting Options	Included optional stability bars Floor placement with plated cone feet
Enclosure Material	Medium density fiberboard with internal bracing
Finish	Charcoal black laminate with wood veneer or gloss accent panels

Terms and Conditions

Terms and Conditions: Details are available on request, please contact your Dealer for more. Note that these terms and conditions do not affect your statutory rights.

Shipping: When you receive your new subwoofer, please check to ensure there is no damage. If after unpacking you discover any damage that may have been caused by transportation on your product, we request you contact SVS or if outside the USA your Dealer immediately and if possible, provide a photo of damage in question to them to ensure the fastest possible correction to the situation.

Warranty: The product has a 3 year warranty against defects in materials and workmanship. Upon return, the products will be repaired, and redelivered. Naturally, this warranty does not cover any product subjected to misuse or accidental damage.

The bottom line: We're proud of these subwoofers and want you to be as happy owning one, as we are selling one (or more) to you. E-mail your [Dealer](#) if you have any warranty question or contact [SVS directly if in North America](#).

SV Sound

SV Sound International LLC
6420 Belmont Ave.
Liberty, Ohio 44420

Fax: 703-997-2603

Phone: 703-845-1472

Email: custservice@svsound.com

